

YZF DTM3 CAL3 SETTING SHEET Ver.01

CIRCUIT **Bamboo circuit**

- INDOOR OUTDOOR
- DIRT ASTROTURF CARPET GLASS WOOD
- WET DRY DUSTY SMOOTH BUMPY
- HARD PACKED CLAY BIUE GROOVE _____
- LOW TRACTION MED TRACTION HIGH TRACTION

DRIVER **Nana Kaiho**

DATE **04/Oct/2020**

FRONT

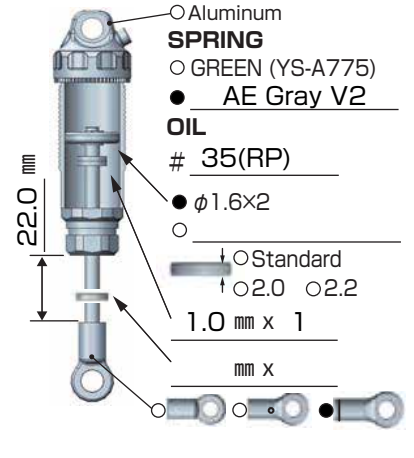
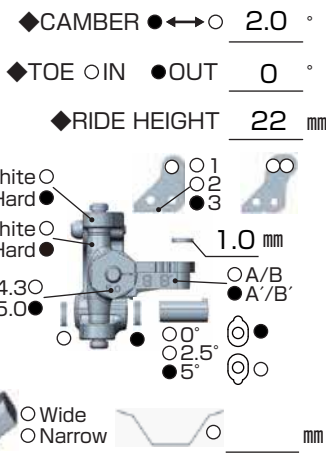
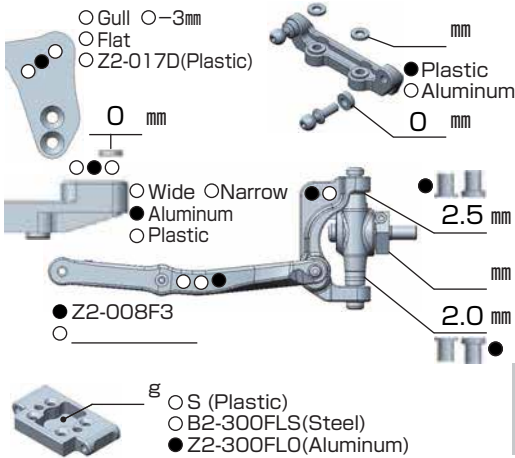

REAR

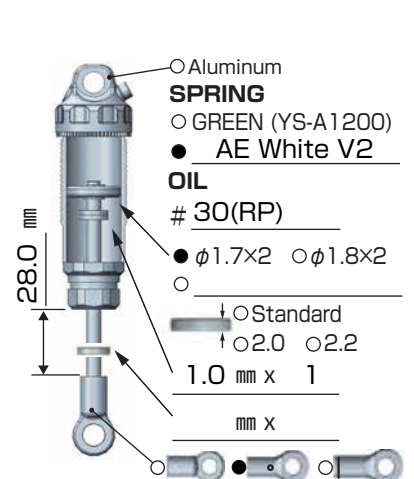
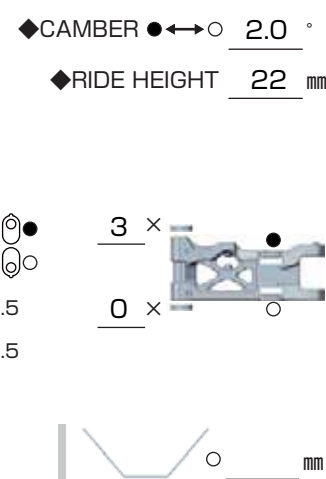
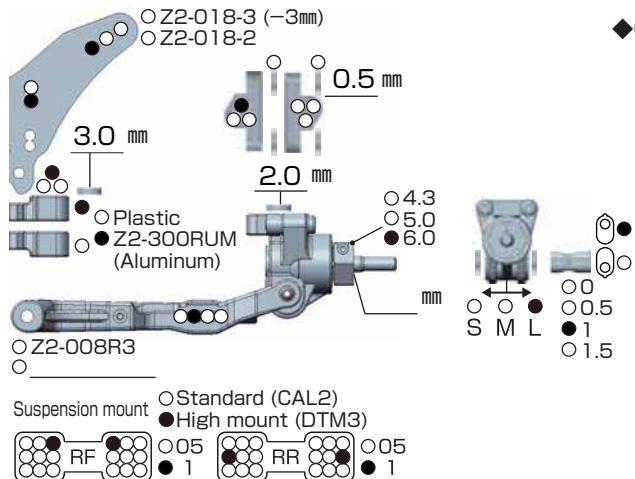

DRIVE

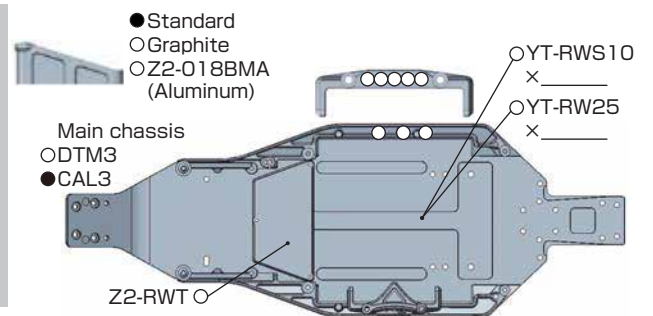

TIRE

FRONT
 TIRE \rightarrow PROLINE 4-lib M4
 INSERTS \rightarrow Sweep Mold inner
 WHEELS \rightarrow YOKOMO

REAR
 TIRE \rightarrow PROLINE Hole shot M4
 INSERTS \rightarrow YOKOMO T-16
 WHEELS \rightarrow YOKOMO

OTHER

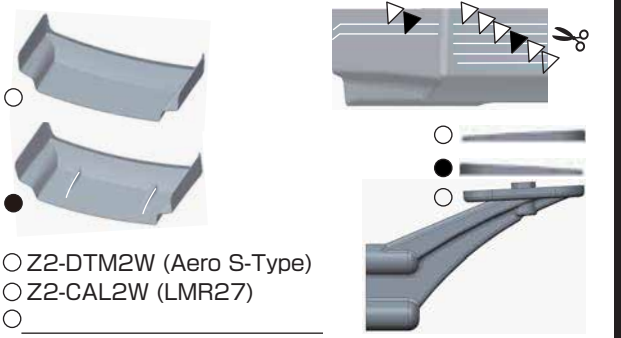

COMMENT
 Body:P2K