

B-MAX4 II

SETTING SHEET Ver.04

CIRCUIT

Cactus Classic

- INDOOR OUTDOOR
- WET DRY DUSTY BUMPY OTHER
- LOW TRACTION MED TRACTION HIGH TRACTION
- SMOOTH BUMPY BLUE GROOVE ASTROTURF
- CARPET WOOD CLAY

DRIVER Lee Martin

DATE 2015/ 15 /MAR

FRONT

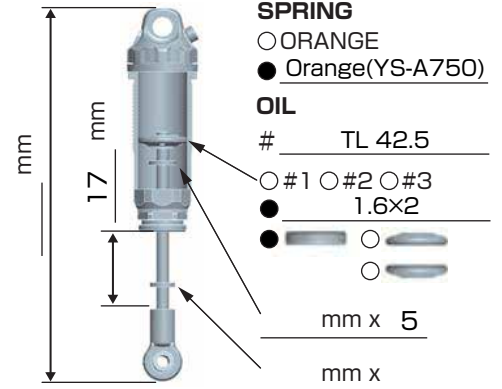
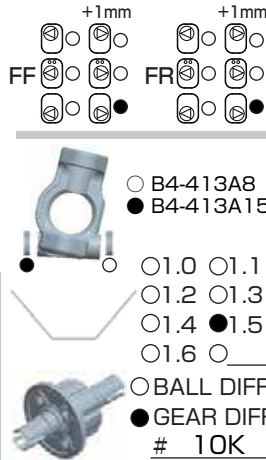
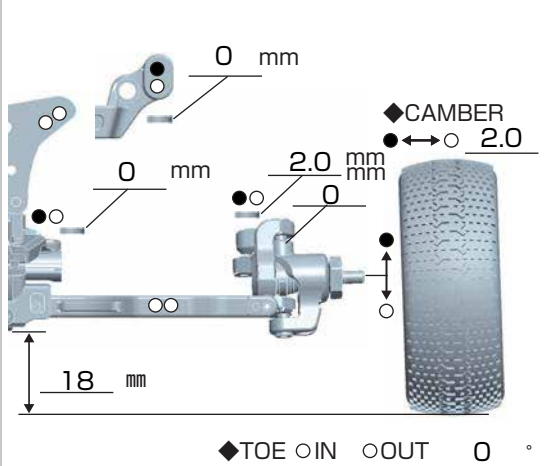

REAR

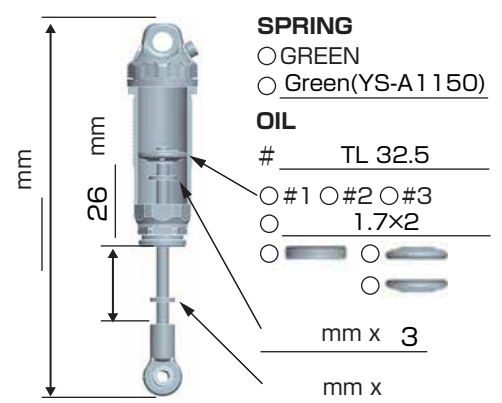
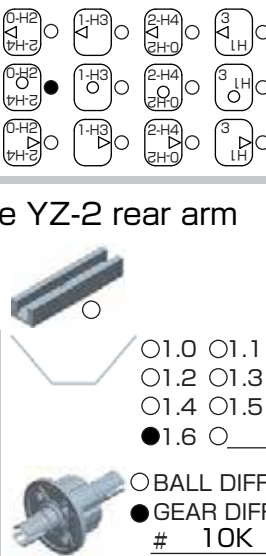
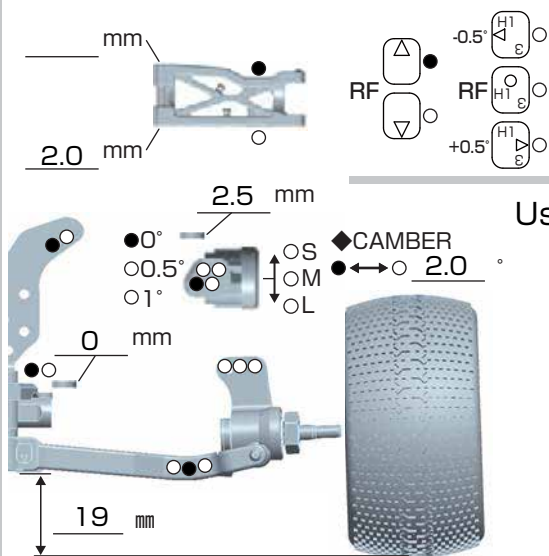

Use YZ-2 shocks

DRIVE

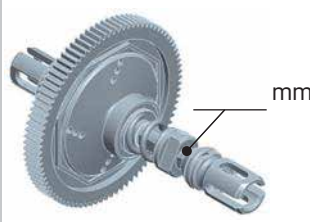

MOTOR \rightarrow Much More 6.5T Bonded Sintered mm
GEAR \rightarrow Spur 84 T / Pinion 18 T : 2.35
BATTERY \rightarrow Protek
ESC Racing Performer X Series
 BL-R3 Much More

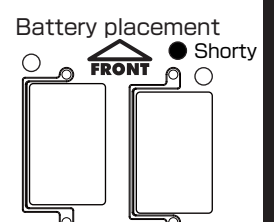

TIRE

FRONT
TIRE \rightarrow Pro-line Prime / MC
INSERTS \rightarrow Pro-line
WHEELS \rightarrow Pro-line

REAR
TIRE \rightarrow Pro-line Prime / MC
INSERTS \rightarrow Pro-line
WHEELS \rightarrow Pro-line

OTHER

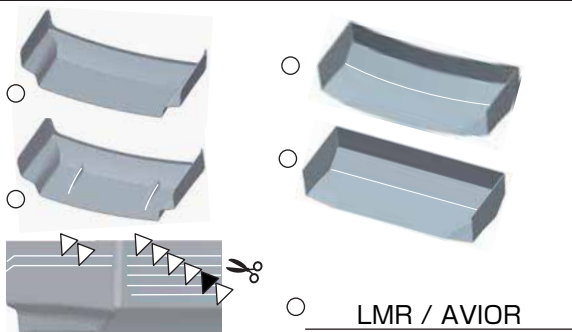

COMMENT

All titanium screw
All titanium turn buckle
YZ-2 Drive shaft (Z2-010R)
YZ-2 Rear arm (Z2-008R)
YZ-2 Shocks (Z2-S1S/Z2-S1L)