

B-MAX4 III

SETTING SHEET Ver.04

CIRCUIT

2014 EURO

- INDOOR ○ OUTDOOR
- WET ● DRY ○ DUSTY ○ OTHER
- LOW TRACTION ○ MED TRACTION ○ HIGH TRACTION
- SMOOTH ○ BUMPY ○ BLUE GROOVE ○ ASTROTURF
- CARPET ○ WOOD

DRIVER

Lee Martin

DATE

2014/07/19

FRONT

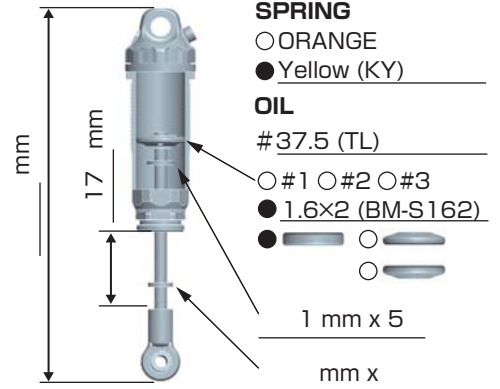
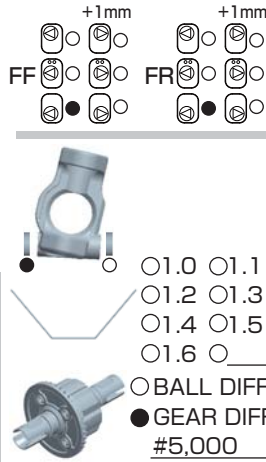
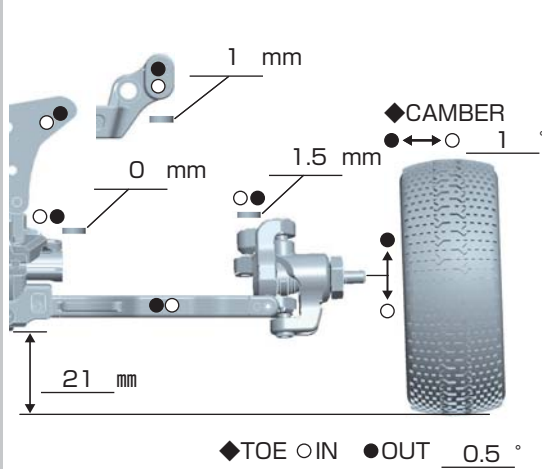

REAR

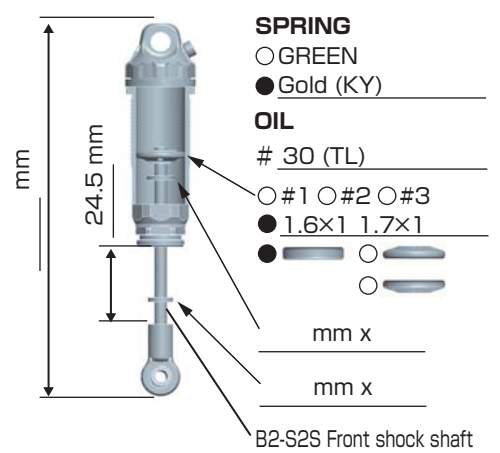
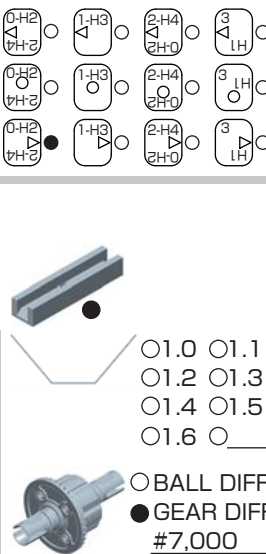
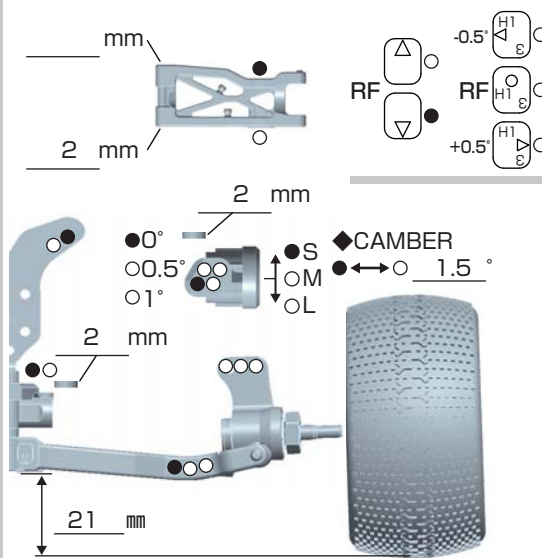

DRIVE

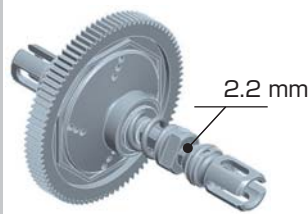

- MOTOR ⇨ R.P. M series 6.5T ○ Bonded
- GEAR ⇨ Spur 84T / Pinion 19 T : 2.35 ○ Sintered
- BATTERY ⇨ ProTek 5500mAh 100C Saddle Battery
- ESC ○ Racing Performer X Series
- BL-R3 ● Viper VTX10 BE

Battery placement

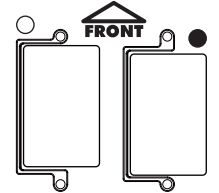

TIRE

FRONT

- TIRE ⇨ JC Bar Codes (Hand out)
- INSERTS ⇨ PL 2 Stage
- WHEELS ⇨ B4-821W

REAR

- TIRE ⇨ JC Bar Codes (Hand out)
- INSERTS ⇨ PL 2 Stage
- WHEELS ⇨ B4-827W

OTHER

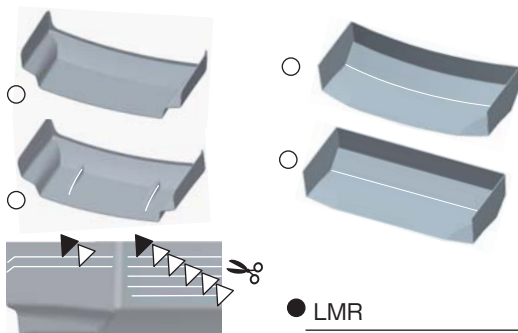

COMMENT

- B4-LWS Lightweight chassis conv.
- B4-304MG Graphite center mount plate
- B4-TBS Titanium turnbuckle set
- B4-415R00 Aluminum rear hub career 0°
- B4-TSS Titanium screw set
- B2-S40 Shock bottom cap (with stepped collar)
- B4-200SS Graphite center link support
- B4-303A Aluminum input shaft
- B4-CB68A Aluminum center bone 68mm
- B4-CB76A Aluminum center bone 76mm
- B2-S812A Aluminum shock cap
- B4-101H B-MAX4 III body (Heavy duty)