



# SETTING SHEET Ver.02

## CIRCUIT

## Cactus Classic

- INDOOR ○ OUTDOOR
- WET ○ DRY ○ DUSTY ○ OTHER CRY
- LOW TRACTION ● MED TRACTION ● HIGH TRACTION
- SMOOTH ● BUMPY ○ BLUE GROOVE ○ ASTROTURF
- CARPET ○ WOOD

DRIVER

Lee Martin

DATE

2015/ 15 / MAR

### FRONT

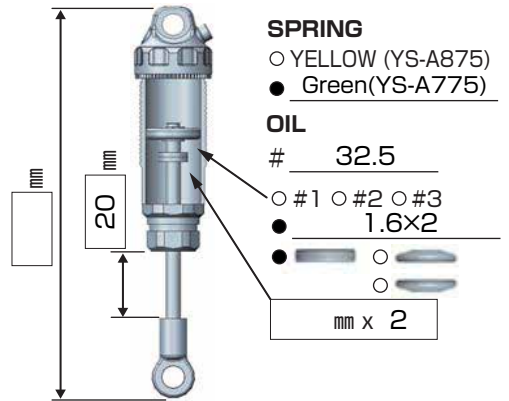
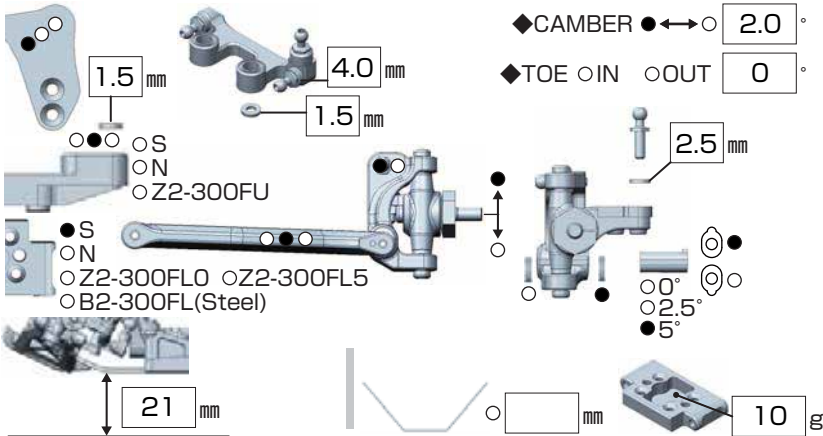

### REAR

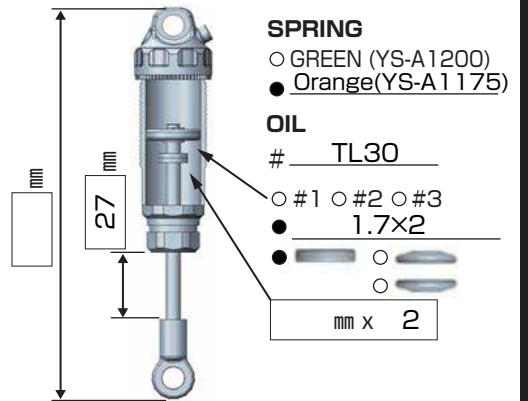
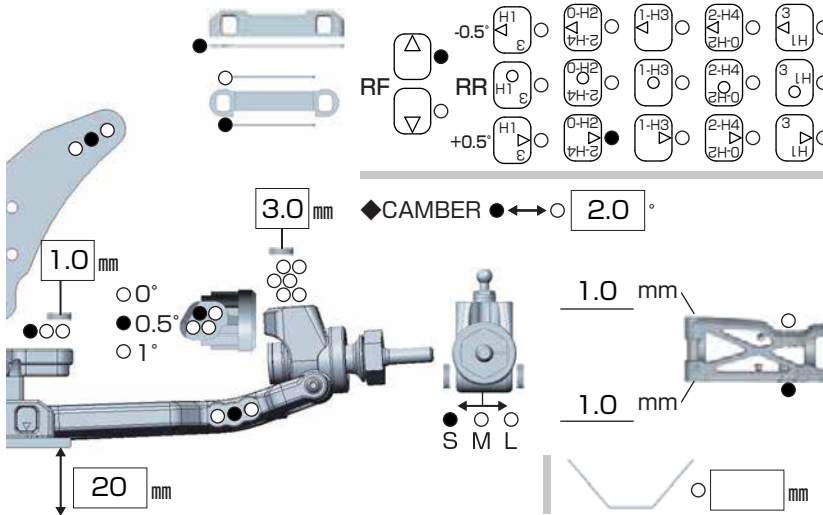

### DRIVE



- MOTOR ⇨ Much More 7.5T ○ Bonded ○ Sintered mm  
 GEAR ⇨ Spur 80 T / Pinion 23 T : 2.6  
 BATTERY ⇨ Protek  
 ESC ○ Racing Performer X Series  
 ○ Much More

#### Battery placement

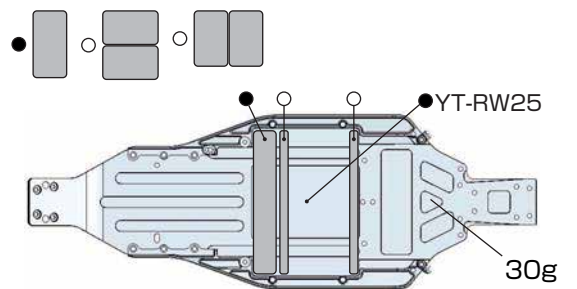

### TIRE

- |              |                                   |             |                                   |
|--------------|-----------------------------------|-------------|-----------------------------------|
| <b>FRONT</b> | <b>TIRE</b> ⇨ Pro-line Prime / MC | <b>REAR</b> | <b>TIRE</b> ⇨ Pro-line Prime / MC |
|              | <b>INSERTS</b> ⇨ Pro-line         |             | <b>INSERTS</b> ⇨ Pro-line         |
|              | <b>WHEELS</b> ⇨ Pro-line          |             | <b>WHEELS</b> ⇨ Pro-line          |

### OTHER

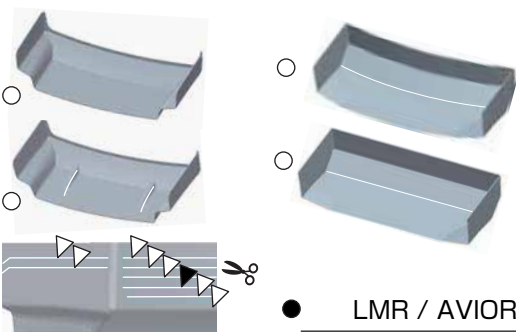

#### COMMENT

- B-MAX4III Rear arm (B4-008R)
- B-MAX2 Drive shaft (B2-010R)
- Aluminum rear link mount (Release soon)
- All titanium screw
- All titanium turn buckle